

Author

Peter Nystrom
President
TSi Power Corp



Protection Of Telecom Sites In Countries With Unstable AC Mains

AC mains voltages frequently fluctuate beyond the IEC assumed standard of a 184 to 264VAC input range.

BACKGROUND

Developing countries often have weak power generation and distribution systems: Frequently resulting in mains voltage fluctuations beyond the 184 to 264VAC input range mandated by the European Norm. The underlying IEC standards assume that power generation and distribution are fairly stable and that voltage excursions will not be outside the specified input window of 184 to 264VAC. Unfortunately, that is not the case in many developing countries throughout the world. Even industrialized nations have their share of problems with AC mains availability. Mains voltages frequently fluctuate beyond the assumed 184 to 264VAC input range.

In the U.S. State of California for example, a failed deregulation scheme coupled with the lack of corrective political will led to rolling blackouts that cut power to millions in early 2001. The desired expansion of generation and distribution capacity in developing countries is also constrained by a shortage of capital and, in some cases, political factors as well. Thus, it appears that the quality of AC mains, for developing countries, is at best uncertain into the foreseeable future.

The expansion of communications networks, such as cellular radio, direct radio access telephony (wireless in the local loop), paging networks, land mobile radio and satellite telephony stations, has led to a rapid increase of installed sites to support these networks. The proliferation of sites sometimes makes it difficult to place a particular site in an ideal location. The site might then be installed in a remote or difficult-to-access location.

The author of this article has worked with infrastructure manufacturers and operators to address power-related reliability problems, which can be very expensive if not addressed properly--especially for remote and hard-to-reach locations. This paper aims to give readers some helpful hints when addressing their own power-related reliability concerns.



TSi Power Corporation
1103 West Pierce Ave
Antigo, Wisconsin 54409
800.874.3160
Fax 715.623.2426
www.tsipower.com
sales@tsipower.com
Copyright © 2001-2003



THE PROBLEM

The power converters used in modern AC-DC rectifiers, UPS and AC-DC switchmode power supplies, are typically based on the IEC input range of 184 to 264VAC. AC induction motors are sensitive to both high and low mains voltage, where low voltage can cause rotor lockup following a dip in mains voltage; and to saturation causing tripping of circuit breakers, as a result of high mains voltage. Transformers and other 50/60Hz magnetics can easily get saturated when exposed to high input voltage, particularly at 50Hz, when the magnetization curve of steel becomes non-linear much quicker than for 60Hz.

AC induction motors are sensitive to both high and low mains voltage

Causes of Power Supply Failure

- **Sags and under-voltages** can cause component overheating and destruction of MOS-FETs from over-current.
- **Surges and over-voltages** can cause component overheating, destruction of MOS-FETs, or can trigger other electronic components such as SCRs, MOVs and input capacitors may be destroyed if they are rated too close to the line voltage.
- **Component overheating** reduces the life and **deteriorates the real reliability** as opposed to the estimated reliability based on steady-state conditions of the product.
- **False triggering** of other components can create nuisance alarm tripping or, worse, can cause overheating or destruction of other components.
- Typical EMI filters are not well damped. This has a dramatic effect on any voltage disturbances, resulting in oscillations inside the EMI filter under any transitional conditions. **Severe voltage surges may result from fly-back from saturated inductors** looking for a path to release energy.
- **Boost converters can be destroyed by surges** causing increased energy storage in the input filter, when the output capacitor is charged to an unsafe level, depending on capacitance value and the load levels for the DC/DC converter connected to the output of the boost converter.

Causes of Semiconductor Failure:

- Most semiconductor devices are intolerant to surge voltages in excess of their voltage ratings.
- A fast surge (high dv/dt) of a few kV per microsecond can cause a semiconductor to fail catastrophically or may degrade it so as to shorten its useful life.
- Damage occurs when a high reverse voltage is applied to a non-conducting PN junction.
- The PN junction may avalanche at a small point due to the non-uniformity of the electric field. In this case, thermal runaway can occur because of localized heat buildup and cause a melt-through which destroys the junction.

Mains voltages varying between 160 to 330VAC are common in countries like India and Pakistan.

Mains voltages varying between 160 to 330VAC are common in countries like India and Pakistan, but are also found in many other areas. In such cases, installation of unprotected power systems and equipment can lead to an abnormally high failure rate and loss of revenue for both suppliers and users of telecom hardware.



Mains voltage anomalies can be caused by the following:

- **Fault clearing:** where a short circuit occurs on the line and a protection device clears the fault, typically in around 3 cycles. The clearing of a fault results in a short dip and voltage recovers rapidly if the mains are stable. However, recovery can take much longer if the mains are weak, resulting in a protracted voltage sag.
- **Chronic instability:** caused by interaction of voltage stabilizing devices. A good example would be an industrial area with an inadequate incoming power line, thus resulting in unstable mains as loads cycle on and off. Users of power may then install a voltage stabilizer that will draw more current to provide a higher voltage for one facility, with the higher current draw causing a voltage drop for adjacent facilities that in turn draw more power when regulators attempt to correct the mains voltage. The end result can be a total loss of power when current draw exceeds the substation's capability to deliver the required current.
- **Weak generation capacity:** will also result in fluctuating mains when utility customers compete for available power.
- **Rolling brownouts:** can result when the power utility reduces the mains voltage by 10% or more in order to limit power consumption. This approach may work for fixed-resistance loads such as light bulbs, but will not for computer and telecom equipment utilizing switchmode power supplies, as these compensate for low voltage by increasing current draw. The increased current is capable of generating increased internal heat that can lead to power supply failure.
- **Blackouts:** can result when the electric utility cuts off power to selected areas in an attempt to protect major parts of the distribution system from interruptions.

Mitigation devices are often applied as a “bandage,” in the hope that things will get better quickly, to the satisfaction of both the telecom operator and the equipment provider. Unfortunately, applying mitigation devices without understanding the basics can actually aggravate the problem. This is especially true for power-factor-corrected power supplies, as these are more sensitive to mains disturbances than their simpler siblings with rectifier/capacitor inputs. It is the author's experience that power-factor-corrected rectifiers can trip internal protection devices when exposed to rapidly changing mains voltages.

Over-voltage protection (surge protection) against surge voltages, and from load switching and lightning, is governed by rational principles, first outlined by IEC-1312 in the early 1990s. The applicable IEC-Standard: IEC Technical Specification 61312-3 “Requirements of Surge Protective Devices (SPDs)” describes clearly how to coordinate SPDs to ensure that upstream devices (**Figure 1**) progressively handle more energy than the SPD found on the front-end of a power supply, typically a metal oxide varistor. These sensible coordination principles are not always adhered to, which sometimes results in a lack of coordination between SPDs used in a system. This can lead to the destruction of downstream SPDs that clamp before the upstream SPDs, which in turn causes the destruction of the metal oxide varistors in the power supply itself.



FIGURE 1. Coordination of Surge Protection Devices.

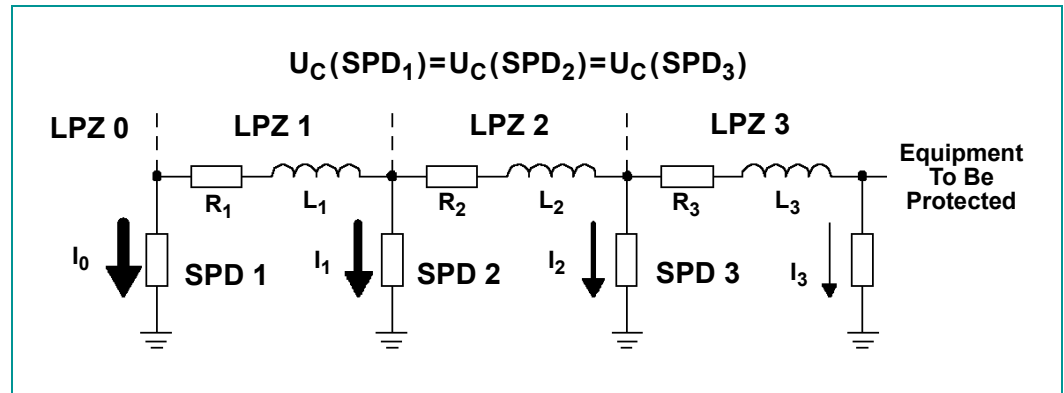

Safety Earthing Systems

Many different earthing systems are in use throughout the world and need to be understood before primary surge protection is implemented. The most common earthing systems are shown below:

TN-S

A separate neutral and ground conductor are run throughout.

TN-S

A separate neutral and ground conductor are run throughout. The ground conductor can be the metallic sheath of the power distribution cable or a separate conductor. All exposed-conductive-parts of the installation are connected to ground

TT

One point of the source of energy is grounded and the exposed-conductive-parts of the installation are connected to independent grounded electrodes

TN-C

Neutral and ground conductors combine in a single conductor throughout the system. All exposed-conductive-parts are connected to the combined N-G conductor.

IT

A system that has no direct connection between live parts and ground. All exposed-conductive-parts of the installation are connected to independent grounding electrodes

TN-C-S

Neutral and ground combine in a single conductor. This system is also known as multiple earthed neutral (MEN). The protective conductor is referred to as the combined neutral and ground conductor. The supply N-G conductor is grounded at a number of points throughout the network and generally as close to the consumer's service entrance as possible. All exposed-conductive-parts are connected to the combined N-G conductor



The most obvious solution is to design power supplies to withstand a much wider input voltage range.

Possible Solutions

The most obvious solution is to design power supplies to withstand a much wider input voltage range, to prevent saturation and resulting energy impulses that cause damage to switching transistors and other circuits. Such changes require more steel in inductors, capacitors with higher voltage ratings, possibly larger circuit boards with greater trace separation, as well as transistors with higher voltage and current ratings. This is not likely, as manufacturers would have to offer special versions with a wide input voltage range or, as a second option, make only power systems that can handle all worldwide markets, regardless of mains quality. This second option is not realistic since customers in countries with a stable mains infrastructure would be penalized.

Designing a protection device that can handle an entire power plant, or racks of power systems, is probably a more economical solution that can be used whenever increased immunity is required. Such a solution can also be used to address problems that occur in the field after installation.

Considerations for Mitigation Devices

Mitigation devices may include a complete solution, or components thereof, if system analysis reveals that essential elements already exist. We will present here a complete solution for the readers' consideration.

Input range of 160 to 330VAC at 50/60Hz without saturation at 50Hz.

Requirements:

1. Input range of 160 to 330VAC at 50/60Hz without saturation at 50Hz.
2. Output range of 184 to 264VAC
3. Over-voltage protection (OVP) with cut-off if output exceeds 264VAC
4. Automatic bypass in case of electronics failure
5. Low impedance
6. Coordinated surge protection
7. Conversion to TN safety earthing system
8. Low weight
9. Reasonable cost
10. High power efficiency and low heat loss

FIGURE 2. An Example Of A Power System For A Cellular Base Station Follows On The Next Page



Figure 2 - An Example of a Global Outdoor UPS System with Protection

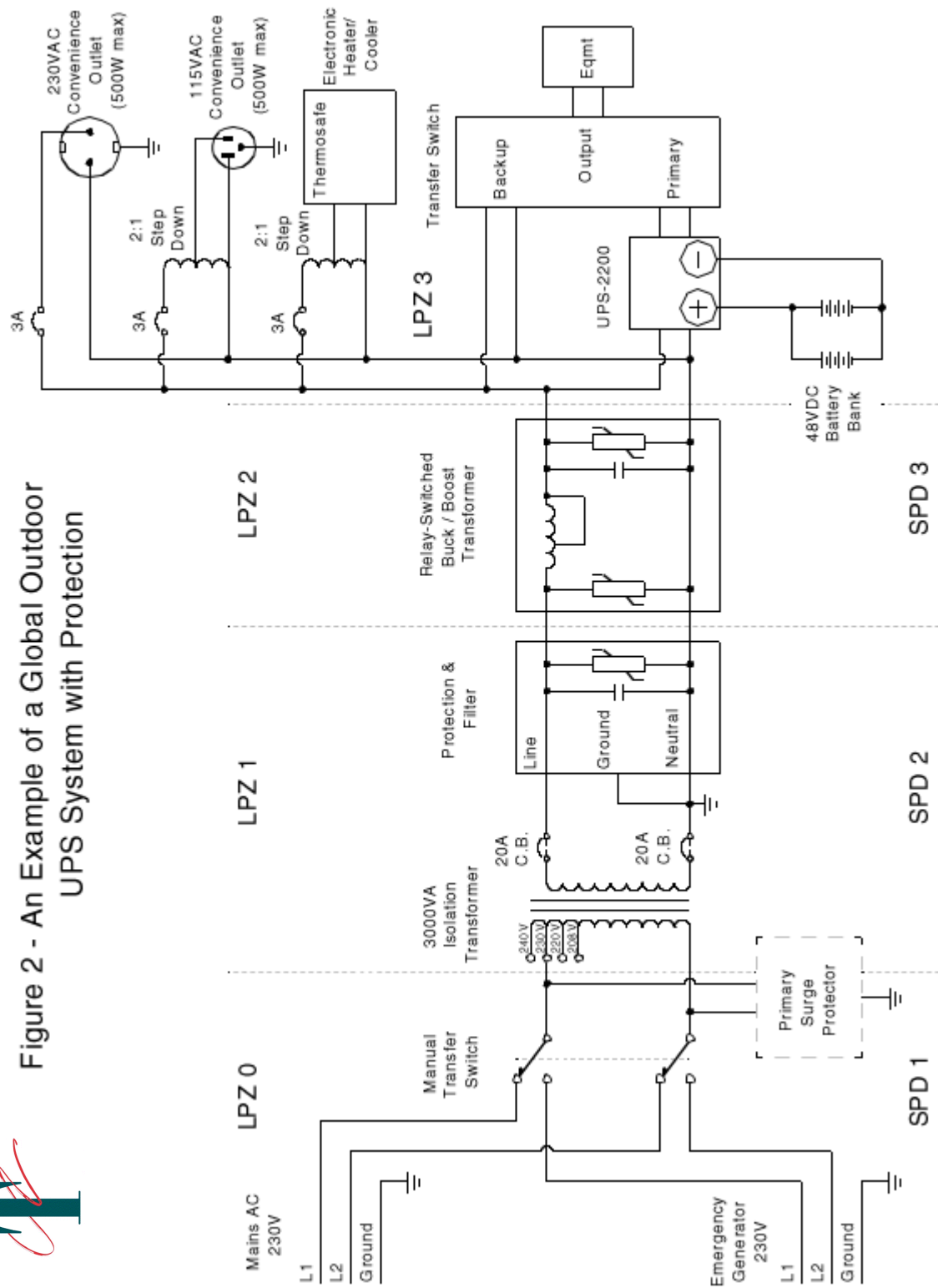



Limitations Of Existing Technologies

Several technologies are available for mitigation devices, each with a distinct set of advantages and drawbacks. Table 1 below provides a summary:

Table 1: Limitations Of Existing Technologies

Technology	Advantages	Drawbacks
Ferroresonant Transformer With Isolation	<ul style="list-style-type: none"> • Reliability • Surge protection • Tight regulation • Fast regulation • Bypass is not required 	<ul style="list-style-type: none"> • Price • Stability • High impedance • Limited voltage input range • Frequency sensitive • Low efficiency • Incompatible with power-factor-corrected power supplies • High weight • Bulky
Tap-Switched Auto-Transformer	<ul style="list-style-type: none"> • Lowest cost • High efficiency • Low impedance 	<ul style="list-style-type: none"> • Slow response • Limited voltage input range • Automatic bypass not available • Requires added isolation transformer to achieve proper surge protection
PWM-Regulated Buck-Boost Transformer	<ul style="list-style-type: none"> • Very tight regulation • Low impedance • Excellent stability • Low weight • Small size • Very high efficiency • Some have automatic bypass 	<ul style="list-style-type: none"> • Medium reliability • Limited voltage input range • Most do not have OVP • Requires added isolation transformer to achieve proper surge protection
Relay-Switched Buck-Boost Transformer With Autobypass And OVP	<ul style="list-style-type: none"> • Very wide input voltage range of 160–330VAC • Low impedance • Excellent stability • Low weight • Small size • Very high efficiency • Automatic bypass 	<ul style="list-style-type: none"> • Requires added isolation transformer to achieve proper surge protection
Variable Transformer With Buck-Boost Transformer	<ul style="list-style-type: none"> • Very tight regulation • Low impedance • Excellent stability • Very high efficiency • Some have automatic bypass 	<ul style="list-style-type: none"> • Very slow • High weight • Bulky • Slow regulation • Can produce excessive voltage following restart after mains failure • Some do not have OVP • Requires added isolation transformer to achieve proper surge protection

Summary

Many equipment malfunctions can be traced back to inadequate infrastructure for power generation and distribution and inadequate installation practices.

The risk of system failure is greater at 50Hz, especially for high mains voltages.

A plethora of safety earthing systems and supply voltages make it difficult to create a simple standard for field installation.

A standardized system of mitigation devices with AC mains stabilization that also meet the requirements of IEC Technical Specification 61312-3 may be the best way to ensure consistent system performance.

About the Author:

Mr. Peter Nystrom has been active in the power protection industry since 1979 and is the founder of two companies. He has also been active as a consultant to major telecommunication equipment manufacturers for several years. Since 1998, he has been the CEO of TSi Power Corporation (located in the state of Wisconsin, USA), a manufacturer of UPS, line conditioner, automatic voltage regulator, automatic transfer switches and DC to AC inverter systems designed to meet the challenging international power conditions.



TSi Power Corporation

1103 West Pierce Ave
Antigo, Wisconsin 54409
715.623.2426
800.874.3160
Fax 715.623.2426
www.tsipower.com
sales@tsipower.com
Copyright © 2003