

**Author**

Peter Nystrom  
President  
TSi Power Corp

## IEC 1312 Surge Protective Device Coordination



## FOUR COORDINATION VARIANTS

### Background

*The purpose of SPD coordination is to successively reduce the lightning threat, in stages (SPD 1, 2 & 3) down to the surge withstand capability of the "vulnerable equipment," without exceeding surge current and voltage ratings of individual SPDs.*

Lightning surges contain significant amounts of energy that needs to be diverted away from the "vulnerable equipment" (system that is to be protected from surges). Electronic equipment, if CE marked, is designed with a certain built-in surge voltage immunity in accordance with IEC 1000-4-5—this level of immunity will be sufficient for the majority of office buildings where the "vulnerable equipment" is located far away from the electric service entrance. Thus, equipment that carries the CE mark will work well without surge protection in many environments. However, when the "vulnerable equipment" is installed close to the electric service entrance, or in an outdoor enclosure, particularly in areas with a poor physical ground (dry sand, rock, etc.), it is often necessary to add external surge protective devices (SPDs). IEC recommends (IEC 1024) that lightning protection zones (LPZ) are established to successively reduce lightning currents, in stages, down to the built-in immunity of the "vulnerable equipment." The number of zones required depends on the structure containing the installation and the "vulnerable equipment." IEC 1024 requires that an SPD is installed at each zone boundary? the surge current and voltage ratings of individual SPDs must not be exceeded.

This paper explains the purpose and concept of surge protective device (SPD) coordination in accordance with the IEC 1312 standard.

### Purpose of Coordination

To successively reduce the lightning threat, in stages (SPD 1, 2 & 3) down to the surge withstand capability of the "vulnerable equipment," without exceeding surge current and voltage ratings of individual SPDs.



**TSi Power Corporation**  
1103 West Pierce Avenue  
Antigo, WI 54409  
USA  
715.623.0636  
800.874.3160  
Fax 715.623.2426  
sales@tsipower.com  
www.line-conditioner.com



## Variant I

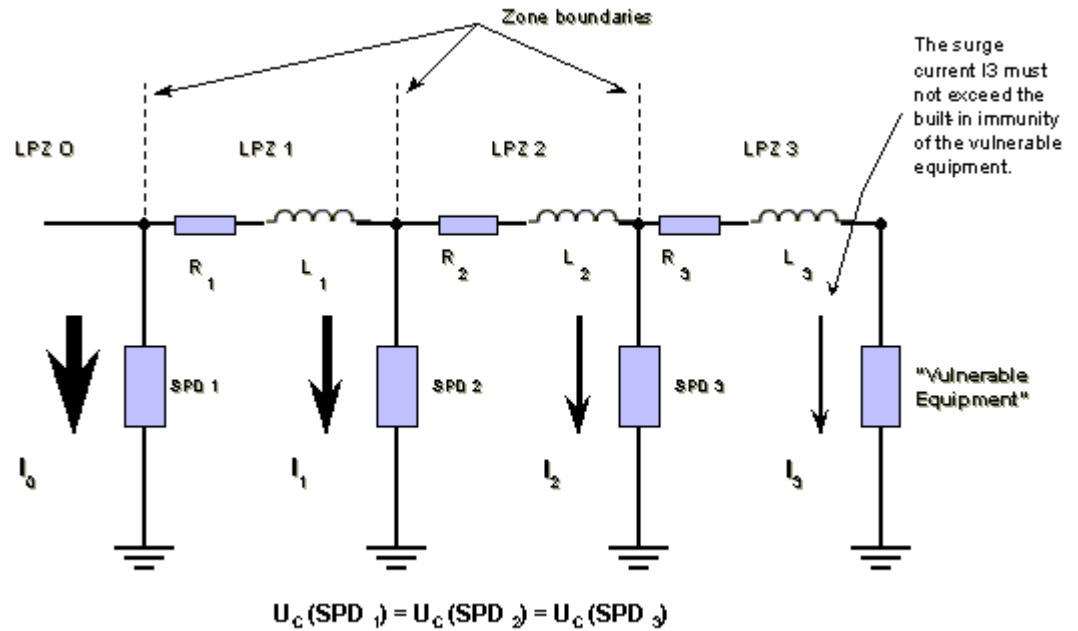

Figure 1

## Coordination Concepts

IEC 1312 defines four coordination "variants." The first three utilize individual single-port SPDs while the fourth variant is a two-port hybrid design.

### Variant I

Shown in Figure 1, the rated voltage of SPDs is identical and coordination is achieved by separating each SPD by means of series impedance. Variant I is not recommended by the IEC, probably because it would require approximately 30' (10 m) of wire or separate inductors between each SPD, which is not practical when installing equipment close to the electric service entrance, or in outdoor enclosures.

### Variant II

Shown in Figure 2, the rated voltages of SPDs are stepped so that the SPD in the "vulnerable equipment" has the highest rated voltage and SPD 3, 2 & 1 have progressively lower rated voltages, thus assuring that each upstream SPD would divert progressively higher currents. Variant II is difficult to implement as most power supplies, uninterruptible power systems and telecom rectifiers, rated for 230VAC, use input SPDs with a 275Vrms rating. Thus, stepping down rated voltage, would cause SPD 1 and 2 to be destroyed by normal line voltage fluctuations—experience has shown that fluctuations of plus 10% resulting in 250V is not unusual.

*Variants I, II & III utilize individual single-port SPD's. Variant IV is a two-port hybrid design.*



### Variant II

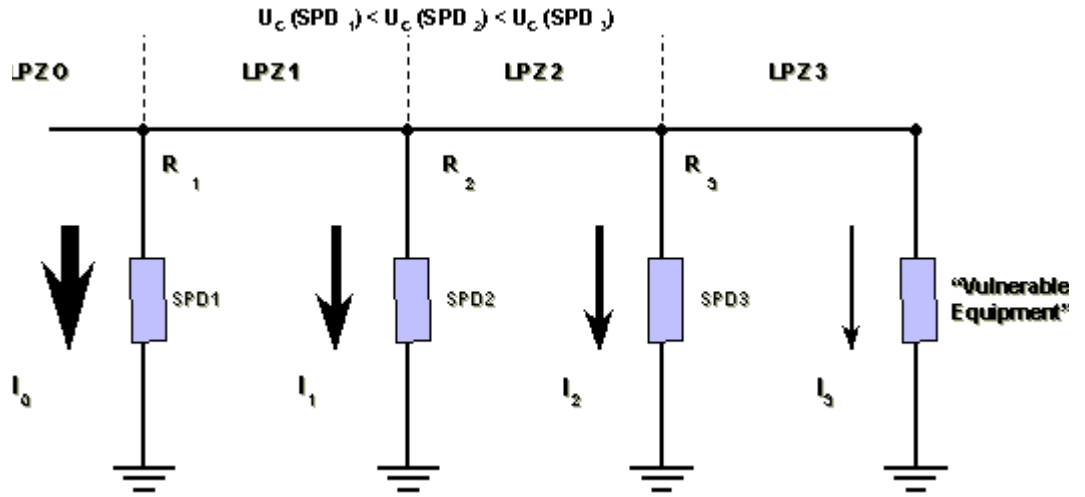

Figure 2

*Variant III is a better choice than I or II as the spark gap is insensitive to fluctuations in line voltage.*

### Variant III

Shown in Figure 3, includes a component with a non-linear current/voltage characteristic, such as a spark gap. The SPD 1 spark gap would divert the majority of the surge current and output a combined wave, similar to ANSI/IEEE C62.41-1991, Category B3, Combination Wave, 3000A, 6000V, to downstream SPDs 2 and 3. The voltage ratings of SPD 2 and 3 are identical, but each device will handle considerably less current thanks to the much higher energy handling capability of spark gap SPD 1. Variant III is a better choice than I or II as the spark gap is insensitive to fluctuations in line voltage. However, spark gap follow-on, short-circuit current may be an issue, and MOVs will still be sensitive to line voltage fluctuations.

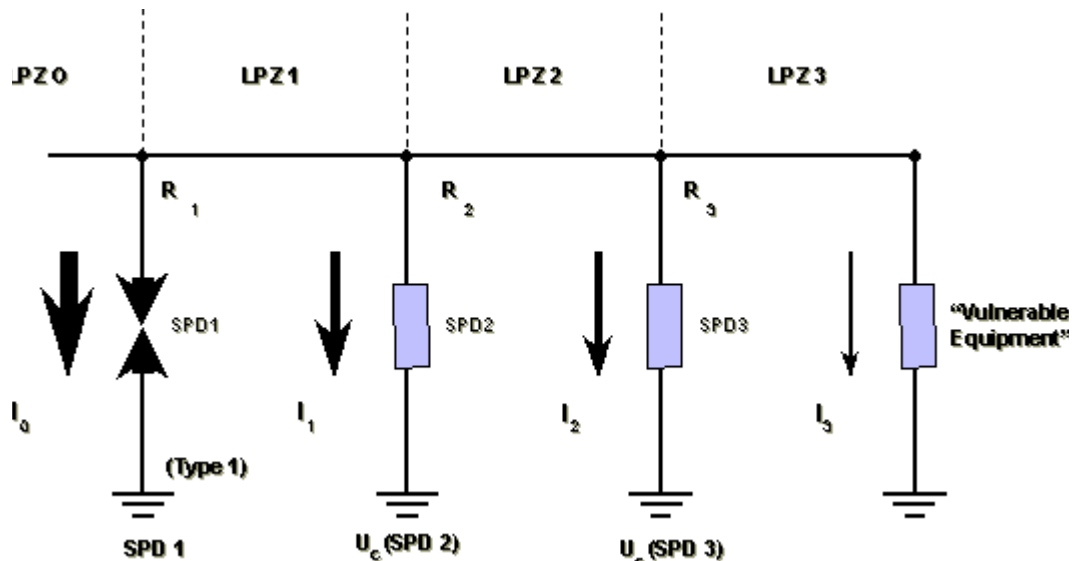

Figure 3

## Variant IV

Figure 4 shows a two-port hybrid device that incorporates cascaded stages of SPDs internally coordinated with series impedances. A hybrid device can be designed to maximize performance while reducing the undesirable characteristics of spark gaps and SPDs based on varistor or silicon-avalanche-diode technology. The use of a hybrid device eliminates the need to coordinate surge protective devices, but does not eliminate sensitivity to prolonged line over voltage.

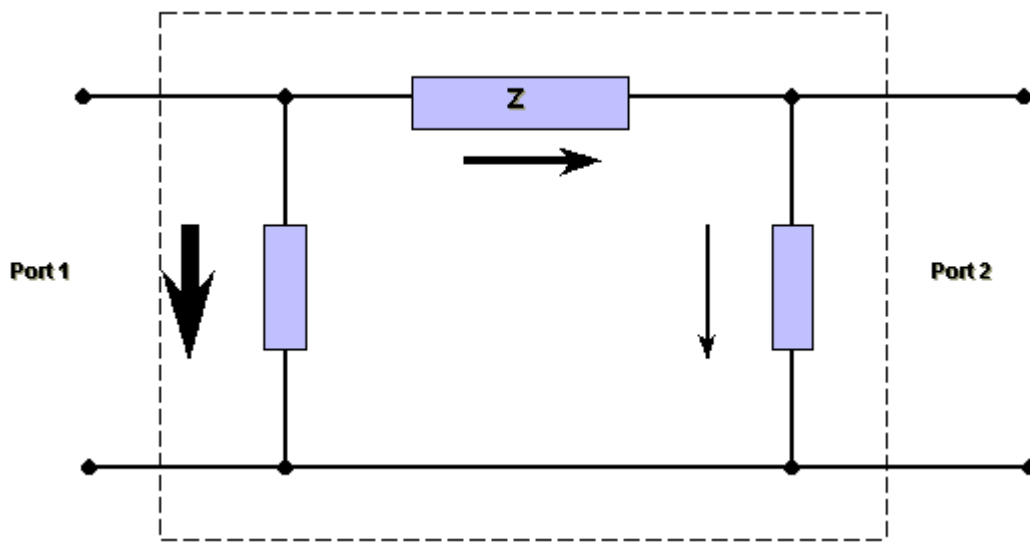

Figure 4

## Summary

Equipment designed to conform to CE requirements has a built-in surge immunity level that is sufficient in most office applications. However, equipment installed close to the electric service entrance or in an outdoor enclosure, particularly in areas with a large number of lightning days, requires additional protection—especially if the physical ground is poor. Surge protective devices require coordination to perform well. The remnant voltage of the SPD closest to the "vulnerable equipment," shall not exceed its built-in immunity level. Coordination of surge protective devices is not always easy and the best solution may be a two-port, hybrid device, which will simplify the planning and installation process. High line voltage will destroy varistor and silicon-avalanche devices that are rated too close to the line voltage and must be considered when planning for protection in areas with unstable power lines.

## About the Author

Mr. Peter Nystrom has been active in the power protection industry since 1979 and is the founder of two companies. He has also been active as a consultant to major telecommunication equipment manufacturers for several years. Since 1998, he has been the CEO of TSi Power Corporation (located in Wisconsin, USA), a manufacturer of UPS, line conditioner, automatic voltage regulator, and DC to AC inverter systems designed to meet the challenging international power conditions.



**TSi Power Corporation**  
1103 West Pierce Avenue  
Antigo, WI 54409  
USA  
715.623.0636  
800.874.3160  
Fax 715.623.2426  
sales@tsipower.com  
www.line-conditioner.com

Copyright © 2004 TSi